

# Protein Science

## Novel fold of VirA, a type III secretion system effector protein from *Shigella flexneri*

Jamaine Davis, Jiawei Wang, Joseph E Tropea, Di Zhang, Zbigniew Dauter, David S. Waugh and Alexander Wlodawer

*Protein Sci.* published online Sep 11, 2008;  
Access the most recent version at doi:[10.1110/ps.037978.108](https://doi.org/10.1110/ps.037978.108)

---

<b>P&lt;P</b>	Published online September 11, 2008 in advance of the print journal.
<b>Accepted Preprint</b>	Peer-reviewed and accepted for publication but not copyedited or typeset; preprint is likely to differ from the final, published version.
<b>Email alerting service</b>	Receive free email alerts when new articles cite this article - sign up in the box at the top right corner of the article or <a href="#">click here</a>

---

### Notes

---

Advance online articles have been peer reviewed and accepted for publication but have not yet appeared in the paper journal (edited, typeset versions may be posted when available prior to final publication). Advance online articles are citable and establish publication priority; they are indexed by PubMed from initial publication. Citations to Advance online articles must include the digital object identifier (DOIs) and date of initial publication.

---

To subscribe to *Protein Science* go to:  
<http://www.proteinscience.org/subscriptions/>

---

**Novel fold of VirA, a type III secretion system effector protein from *Shigella flexneri***

Jamaine Davis<sup>1</sup>, Jiawei Wang<sup>2,3</sup>, Joseph E. Tropea<sup>4</sup>, Di Zhang<sup>5</sup>, Zbigniew Dauter<sup>3</sup>,

David S. Waugh<sup>5</sup> and Alexander Wlodawer<sup>1\*</sup>

<sup>1</sup>Protein Structure Section, Macromolecular Crystallography Laboratory, NCI,  
Frederick, MD 21702, USA

<sup>2</sup>SAIC-Frederick Inc., Basic Research Program, Frederick, MD 21702, USA

<sup>3</sup>Synchrotron Radiation Research Section, Macromolecular Crystallography Laboratory, NCI,  
Argonne, IL 60439, USA

<sup>4</sup>Protein Purification Core, Macromolecular Crystallography Laboratory, NCI,  
Frederick, MD 21702, USA

<sup>5</sup>Protein Engineering Section, Macromolecular Crystallography Laboratory, NCI,  
Frederick, MD 21702, USA

\*To whom reprint requests and correspondence should be addressed:

Tel: 301-846-5036; FAX: 301-846-6322; E-mail: [wlodawea@mail.nih.gov](mailto:wlodawea@mail.nih.gov)

**Abstract**

VirA, a secreted effector protein from *Shigella sp.*, has been shown to be necessary for its virulence. It was also reported that VirA might be related to papain-like cysteine proteases and cleave  $\alpha$ -tubulin, thus facilitating intracellular spreading (Yoshida et al., Science 314, 985, 2006). We have now determined the crystal structure of VirA at 3.0 Å resolution. The shape of the molecule resembles the letter “V”, with the residues in the N-terminal third of the 45 kDa molecule (some of which are disordered) forming one clearly identifiable domain, and the remainder of the molecule completing the V-like structure. The fold of VirA is unique and does not resemble that of any known protein, including papain, although its N-terminal domain is topologically similar to cysteine protease inhibitors such as stefin B. Analysis of the sequence conservation between VirA and its *E. coli* homologs EspG and EspG2 did not result in identification of any putative protease-like active site, leaving open a possibility that the biological function of VirA in *Shigella* virulence may not involve direct proteolytic activity.

## Introduction

Shigellosis is an infectious disease caused by gram-negative, rod-shaped bacteria from the species *Shigella*. Some strains produce enterotoxin and Shiga toxin, which are very similar to the verotoxin of *Escherichia coli* O157:H7 (Lan & Reeves 2002). People infected with *Shigella* develop diarrhea, fever, and stomach cramps 2-3 days after infection. In children, severe infections accompanied by high fevers are associated with seizures. Although shigellosis is rare in the United States, one bacterial species, *Shigella dysenteriae*, has the potential to cause deadly epidemics in developing regions, necessitating the search for novel drugs (Dutta et al. 2003). The initial steps of *Shigella* infection include their attachment to and subsequent penetration of the epithelial cells of the intestinal mucosa. After infection, the bacteria multiply intracellularly and then spread to adjacent host cells. This spreading is accomplished by destabilization of the cytoplasmic network of the host and thereby results in the destruction of tissues (Parsot 2005).

Virulent species of *Shigella* rely on a type III secretion system (T3SS) to deliver a small number of proteins, termed effectors, into the cytosol of host cells where they subvert mechanisms that control the actin cytoskeleton so as to promote invasion and cell-to-cell spreading (Schroeder & Hilbi 2008). One of these effectors is the 45 kDa protein VirA, which creates a path that enables the bacteria to move through the dense, organized cytoplasmic network of the host cell (Ogawa et al. 2008). *Shigella* variants that lack a functional *virA* gene are unable to move through the cytoplasm and the invasiveness of these *virA* mutants is attenuated, suggesting that VirA is essential for *Shigella* virulence (Yoshida et al. 2006). It was proposed that VirA functions as a cysteine protease that selectively degrades  $\alpha$ -tubulin (Yoshida et al. 2006). However, how VirA may recognize and degrade  $\alpha$ -tubulin but not  $\beta$ -tubulin substrates remains unclear.

The only currently known homologs of VirA are the products of *espG* genes found in enteropathogenic and enterohemorrhagic *E. coli* (EPEC and EHEC), as well as in pathogenic *Citrobacter rodentium* (Mundy et al. 2004). It has been shown that, like VirA, EspG disrupts microtubules in fibroblasts and non-polarized epithelial cells (Shaw et al. 2005). Interestingly, a study conducted by Elliott et al. (Elliott et al. 2001), demonstrated that the EPEC *espG* gene can rescue invasion of a *Shigella* which contains a mutation inactivating *virA*.

Seeking to gain further insight into the function of VirA, including its reported ability to process  $\alpha$ -tubulin but not  $\beta$ -tubulin, we determined the crystal structure of the selenomethionine (SeMet)-substituted protein and refined it with data extending to 3 Å resolution. We found the fold of full-length VirA to be novel, without any resemblance to papain-like cysteine proteases, whereas the N-terminal domain shares limited similarity to cystatin A and stefin B, protein inhibitors of cysteine proteases. Although VirA was reported to cleave  $\alpha$ -tubulin, we have not found any structural features that resemble the active sites of known proteases. Thus, the mode of action of this unusual protein requires further study.

## Results and Discussion

The structure of recombinant VirA was solved by single-wavelength anomalous diffraction (SAD) of a single crystal of SeMet-substituted protein. The enzyme was expressed in *E. coli*, purified to homogeneity, and crystallized using vapor-diffusion technique. The crystals belong to the monoclinic space group *C2*, with unit cell parameters  $a=150.3$  Å,  $b=170.9$  Å,  $c=46.2$  Å,  $\beta=104.9^\circ$ , and diffract to 3 Å resolution. Each asymmetric unit contains two molecules of VirA, resulting in a Matthews coefficient  $V_m$  (Matthews 1968) of  $3.2$  Å<sup>3</sup>/Da and a solvent content of 61%. Due to the presence of considerable disorder and to limited resolution of diffraction data we were able to trace only 684 residues out of 800 expected in the dimeric

protein. The residues modeled in each of the crystallographically independent molecules are 1-13, 58-310, and 315-399. Assignment of the sequence to the traced chain was facilitated by identifying the locations of all SeMet residues, based on the anomalous signal of the selenium atoms. However, the identification of the N-terminal 13 residues that form a short helix is only tentative since their sequence does not contain strong markers. Nevertheless, despite the relatively low resolution of the diffraction data, we consider the tracing of the visible parts of the polypeptide chain (with the exception of the N terminus) to be unambiguous.

The refined structure reveals two independently folded domains that resemble the letter “V” (Fig. 1A). The partially disordered N-terminal domain includes residues 1-130, whereas the larger C-terminal domain encompasses residues 131 through 400. The current model consists of twelve  $\alpha$  helices and twelve  $\beta$  strands, including a four-stranded antiparallel  $\beta$ -sheet located in the N-terminal domain and a six-stranded antiparallel  $\beta$ -sheet located in the C-terminal domain (Fig. 1B). A noteworthy feature of the structure is a long, serine-rich helix  $\alpha$ 10 (287-306) that appears to stabilize the dimer in the crystal (and, presumably, also in solution, since VirA appears to migrate as a dimer on native gels and on size-exclusion columns). That helix is responsible for most of the interactions in the dimer (Fig. 1C). The area buried upon dimer formation is 2487  $\text{\AA}^2$  per subunit.

The N-terminal domain of the VirA molecule starts with a stretch of 13 residues disconnected from the rest of the model, putatively assigned as 1-13, that includes small helix  $\alpha$ 1 (residues 6-11). A perpendicularly oriented second helix  $\alpha$ 2 leads, through an extended linker region, to a four-stranded antiparallel  $\beta$ -sheet ( $\beta$ 1- $\beta$ 4), followed by helix  $\alpha$ 3, which ends the first domain. The C-terminal domain begins with a short strand  $\beta$ 5 followed by helix  $\alpha$ 4, which is partially shielded by the six-stranded antiparallel  $\beta$ -sheet. The loop extending from helix  $\alpha$ 4

wraps around this sheet and connects to helix  $\alpha 5$  which is followed by  $\alpha 6$ ,  $\alpha 7$  and  $\alpha 8$ , forming a small helical bundle. Helix  $\alpha 9$  protrudes through the back end of the bundle and loops around to the long  $\alpha 10$  helix situated behind the main sheet and concludes with a short helix  $\alpha 11$ , followed by the last helix  $\alpha 12$ .

One of the reasons cited by Yoshida et al. (2006) for postulating cysteine protease-like activity of VirA was the loss of the apparent enzymatic activity when Cys34 (Fig. 2A) was mutated to a serine. The region surrounding this putative active site is disordered in our current model and no other part of the protein bears any resemblance to the structure of papain. The N-terminal regions of proteins exported by the type III secretion system are frequently disordered (Galan & Wolf-Watz 2006), since these areas provide export signals, and a similar situation might exist in the case of VirA.

By creating a series of truncated proteins, a previous study identified the tubulin-binding region of VirA to contain residues 224 through 315 (Yoshida et al. 2002). Structurally, these residues comprise the helices  $\alpha 7$ - $\alpha 10$ . However, as mentioned above, helix  $\alpha 10$  plays a major role in dimer formation, thus it may not participate in binding tubulin, but rather be necessary for maintaining VirA in a dimeric state. Some of these residues line the inner surface of the “V” structure, and a large cleft present between the two domains is of sufficient size to postulate that it could accommodate a tubulin dimer. It is surprising, though, that the N-terminal domain was not implicated in tubulin binding, although it forms the other arm of the letter “V” and any plausible binding mode would necessitate interactions with both domains.

To determine if the structure of VirA resembles any other proteins with known structure, including the microtubule-destabilizing proteins, we searched the Protein Data Bank for its structural homologs using the DALI server (Holm & Sander 1993). Although no overall strong

similarity to any known proteins was found, the N-terminal domain of VirA exhibits detectable similarity (Z score 4.1) to cysteine protease inhibitors such as stefin B (PDB accession code 1stf) or cystatin A (1gd3). The structure of stefin B was solved in a complex with papain (Stubbs et al. 1990), and 55 out of a total of 98 residues of the inhibitor can be superimposed on residues within the sequence 57-130 of VirA with an r.m.s. deviation of 2.4 Å (Fig. 2B). However, the sequence identity is extremely low at 7%. When the N-terminal domain of VirA is superimposed on the stefin B molecule complexed with papain, the remaining part of VirA does not clash with the papain molecule, making it possible to postulate that the function of VirA might be to create a scaffold for a papain-like cysteine protease, rather than function as an enzyme by itself.

VirA is a member of the EspG family, which also includes *E. coli* EspG, *C. rodentium* EspI, as well as *E. coli* EspG2 (Fig. 2A). Sequence similarity between VirA and EspG is approximately 40% (21% identity), strongly suggestive of similar three-dimensional structures. In addition, these proteins also appear to share functional similarity, since both EspG and EspG2 have been shown to disrupt the microtubule network of intestinal epithelial cells (Elliott et al. 2001). The similarity between VirA, EspG, EspI, and EspG2 suggests a shared fold and mechanism of action within this family.

It has been postulated that all members of the EspG family exhibit cysteine protease-like activity (Smollett et al. 2006; Tomson et al. 2005; Yoshida et al. 2006). In a similar assay, we investigated the ability of VirA to degrade  $\alpha/\beta$ -tubulin. However, we were unable to detect any proteolytic activity using the purified protein, and the sample of VirA purified by us did not exhibit any microtubule-severing activity in a microscopic assay using rhodamine microtubules (A. Roll-Mecak, personal communication). Even the alignment of the primary structures of these proteins does not provide clear indication that this should be the case. The putative catalytic

residue in VirA, Cys34, cannot be aligned well with its closest equivalent, Cys50 in EspG, whereas the corresponding region of EspG2 completely lacks any cysteine residues (Fig. 2A). No other cysteine throughout the whole sequence is conserved among these proteins. Although a number of serine residues are conserved (Ser14, Ser22, Ser123, Ser227, Ser276, and Ser366), none of them is close to either a conserved histidine or a lysine, which would be necessary to create the minimum catalytic dyad found in serine proteases (Dodson & Wlodawer 1998). Ser14 and Ser22 are located within the disordered fragment of the N-terminal domain, Ser276 is buried, and the remaining conserved serine residues, although found on the surface, do not have partners which could activate them for catalysis. None of the lysines and only a single histidine (His291) is conserved, with the latter residue situated at the beginning of the long stabilizing helix,  $\alpha$ 10, which is on the opposite side of the putative tubulin-binding cleft. Very few conserved residues are found on the protein surface (Fig. 2C) and those that are, do not create a plausible active site, raising a possibility that the reported proteolytic activity of this protein might be due to a so-far undetected protease for which it would act as a binding partner.

## Conclusions

Although the structure of VirA was solved at a resolution of 3 Å and the quality of the refined model is only moderate, we have full confidence that the fold of the protein is described correctly. With the exception of the N-terminal domain that topologically resembles several inhibitors of cysteine proteases, the fold of VirA is otherwise novel. Neither the structure by itself nor sequence comparisons with the related proteins EspG and EspG2 support the hypothesis that VirA is a cysteine protease. In particular, the part of the N-terminal domain that contains Cys34, previously postulated to be the catalytic residue, is completely disordered, making it unlikely that it could form a part of the active site. However, the puzzling similarity of

the fold of the N-terminal domain of VirA to the inhibitors of cysteine proteases raises a remote possibility that this virulence effector might function as a scaffold rather than an enzyme. Although this hypothesis currently lacks experimental proof, further investigation of the role of VirA in the virulence of *Shigella* is clearly warranted.

## Materials and Methods

### *Cloning, expression and purification*

The ORF of *Shigella flexneri* VirA was amplified from genomic DNA (American Type Culture Collection, Manassas, VA) by the polymerase chain reaction (PCR) using the following oligonucleotide primers: 5'-GAG AAC CTG TAC TTC CAG GGT ATG CAG ACA TCA AAC ATA ACT AAC C -3' and 5'- GGG GAC CAC TTT GTA CAA GAA AGC TGG GTT ATT AAA CAT CAG GAG ATA TGA TGG -3' (primer R). The PCR amplicon was subsequently used as template for a second PCR with the following primers: 5'-GGG GAC AAG TTT GTA CAA AAA AGC AGG CTC GGA GAA CCT GTA CTT CCA G-3' and primer R (above). The amplicon from the second PCR was inserted by recombinational cloning into the entry vector pDONR201 (Invitrogen, Carlsbad, CA), and the nucleotide sequence was confirmed experimentally. The open reading frame of VirA (M<sub>1</sub>-V<sub>400</sub>), now with a recognition site (ENLYFQ/G) for tobacco etch virus (TEV) protease fused in-frame to its N-terminus, was moved by recombinational cloning into the destination vector pDEST-HisMBP (Tropea et al. 2007) to produce pDZ1952. pDZ1952 directs the expression of a maltose-binding protein (MBP)-VirA fusion protein with an intervening TEV protease recognition site. The MBP contains an N-terminal hexahistidine tag for affinity purification by immobilized metal affinity chromatography (IMAC). The fusion protein was expressed in the *E. coli* strain BL21 (DE3)

CodonPlus-RIL (Stratagene, La Jolla, CA). Cells containing the expression vector were grown to mid-log phase ( $OD_{600} \sim 0.5$ ) at 37 °C in Luria broth containing 100  $\mu\text{g mL}^{-1}$  ampicillin, 30  $\mu\text{g mL}^{-1}$  chloramphenicol and 0.2% glucose. Overproduction of the fusion protein was induced with isopropyl- $\beta$ -D-thiogalactopyranoside at a final concentration of 1 mM for 4 h at 30 °C. The cells were pelleted by centrifugation and stored at -80 °C.

All purification procedures were performed at 4-8 °C. Ten grams of *E. coli* cell paste was suspended in ice-cold 50 mM sodium phosphate (pH 7.5), 200 mM NaCl, 25 mM imidazole buffer (buffer A) containing 2 mM 4-(2-aminoethyl)-benzenesulfonyl fluoride hydrochloride (AEBSF, Roche Molecular Biochemicals, Indianapolis, IN). The cells were lysed with an APV-1000 homogenizer (Invensys, Røhølsvej, Denmark) at 10,000 psi and centrifuged at 30,000  $\times g$  for 30 min. The supernatant was filtered through a 0.22  $\mu\text{m}$  polyethersulfone membrane and applied to a 12 mL Ni-NTA superflow column (Qiagen, Valencia, CA) equilibrated in buffer A. The column was washed to baseline with buffer A and then eluted with a linear gradient of imidazole to 250 mM in buffer A. Fractions containing recombinant His<sub>6</sub>-MBP-VirA were pooled, concentrated using an Amicon YM30 membrane (Millipore Corporation, Bedford, MA), diluted with 50 mM sodium phosphate (pH 7.5), 200 mM NaCl buffer to reduce the imidazole concentration to about 25 mM, and digested overnight at 4 °C with His<sub>6</sub>-tagged TEV protease (Kapust et al. 2001). The digest was applied to a second Ni-NTA superflow column equilibrated in buffer A and the VirA emerged in the column effluent. The column effluent was incubated overnight with 10 mM dithiothreitol (DTT), concentrated using an Amicon YM10 membrane, and applied to a HiPrep 26/60 Sephacryl S-100 HR column (Amersham Biosciences, Piscataway, NJ) equilibrated in 25 mM Tris, 150 mM NaCl, 2 mM Tris(2-carboxyethyl) phosphine hydrochloride buffer. The peak fractions containing recombinant VirA were pooled and

concentrated to 15-20 mg mL<sup>-1</sup> (estimated at 280 nm using a molar extinction coefficient of 36900 M<sup>-1</sup> cm<sup>-1</sup>). Aliquots were flash-frozen in liquid nitrogen and stored at -80°C. The final product was judged to be >95% pure by sodium dodecyl sulfate-polyacrylamide gel electrophoresis. The molecular weight of VirA was confirmed by electrospray mass spectroscopy.

#### *Crystallization and data collection*

Prior to crystallization, VirA was concentrated to a final concentration of 20 mg/mL in 25 mM Tris, 150 mM NaCl, 2 mM Tris (2-carboxyethyl) phosphine hydrochloride buffer. The crystals were grown in hanging drops composed of an equal volume of VirA and 0.8 M sodium/potassium phosphate, pH 6.1 at 22 °C. The crystals were dipped into 0.8 M sodium/potassium phosphate, pH 6.1 + 30% glycerol to cryo-protect before flash-freezing in liquid nitrogen. The diffraction data were collected at the SER-CAT 22-ID beamline (Advanced Photon Source, Argonne National Laboratory). After performing a fluorescence scan the wavelength was tuned to the selenium absorption peak and data were collected at 0.97923 Å wavelength on a MAR300CCD detector. A 3.0 Å SAD data set was collected and then indexed and scaled with the *HKL2000* program suite (Otwinowski & Minor 1997). The statistics of diffraction data and refinement are given in Table 1.

#### *Structure determination and refinement*

The self-rotation function calculated with *POLARRFN* (CCP4 1994) revealed a prominent peak for  $\kappa = 180^\circ$ , indicating the presence of a non-crystallographic 2-fold symmetry axis. *XPREP* (Sheldrick 2001) was used to extract anomalous differences and *SHELXD* (Sheldrick 2008) was employed to locate the positions of selenium sites. *HA\_NCS* (Terwilliger 2002) also located a 2-fold *NCS* axis from the anomalous sites independently. The *NCS* from

anomalous sites had the same orientation as that from the self-rotation function, which verified the validity of the selenium sites. The identified anomalous scattering sites were input for *SAD* phasing to several programs e.g. *SHELXE* (Sheldrick 2008), *SOLVE* (Terwilliger & Berendzen 1999), *PHASER* (McCoy et al. 2007). However, the electron-density maps after density modification were largely uninterpretable and only some helical fragments and turns could be automatically assigned with the program *RESOLVE* (Terwilliger 2003). Because the anomalous sites were verified by the self-rotation function, the residue clusters built by *RESOLVE* at least contained some useful phasing information to improve the map. Thus the modeled fragments and selenium sites were fed back to *PHASER* again to combine the incomplete but partially correct atomic model and the anomalous signal. After several cycles, the combined phase information became stronger, allowing the missing selenium atoms to be located and additional secondary structure elements to be identified. The resulting electron density map was largely interpretable and almost complete model was built with the program *BUCCANEER* (Cowtan 2006). The structure was subsequently refined with *PHENIX.REFINE* (Adams et al. 2002) using NCS, experimental phases, and stereochemical information as restraints (Table 1). Solvent molecules were added with *COOT* (Emsley & Cowtan 2004), in  $F_o-F_c$  electron density peaks close to polar atoms of the protein. The quality of the final model was evaluated with the program *PROCHECK* (Laskowski et al. 1993) and was found to be acceptable, given the limited resolution of the diffraction data (all outliers of the Ramachandran plot are located in the poorly defined loop regions). The coordinates and structure factors have been submitted to the Protein Data Bank under accession code 3ee1.

*Note added during revision*

The structure of an N-terminally truncated VirA, crystallized in a space group different from the full-length protein described here, appeared in press when this manuscript was under review (Germane et al. 2008). The results presented here, in particular concerning the novel fold of VirA and the lack of detectable enzymatic activity, are fully consistent with their observations.

**Acknowledgments**

We would like to thank Dr. Antonina Roll-Mecak for testing the microtubule-severing activity of VirA. Diffraction data were collected at the Southeast Regional Collaborative Access Team (SER-CAT) beamline 22-ID, located at the Advanced Photon Source, Argonne National Laboratory. Use of the Advanced Photon Source was supported by the U. S. Department of Energy, Office of Science, Office of Basic Energy Sciences, under Contract No. W-31-109-Eng-38. This project was supported in part by the Intramural Research Program of the NIH, National Cancer Institute, Center for Cancer Research and in part with Federal funds from the National Cancer Institute, NIH, under Contract No. NO1-CO-12400. The content of this publication does not necessarily reflect the views or policies of the Department of Health and Human Services, nor does the mention of trade names, commercial products, or organizations imply endorsement by the U. S. Government.

## References

- Adams, P.D., Grosse-Kunstleve, R.W., Hung, L.W., Ioerger, T.R., McCoy, A.J., Moriarty, N.W., Read, R.J., Sacchettini, J.C., Sauter, N.K., Terwilliger, T.C. 2002. PHENIX: building new software for automated crystallographic structure determination. *Acta Crystallogr.* **D58**:1948-1954.
- CCP4. 1994. Collaborative Computational Project, Number 4, 1994. The CCP4 Suite: Programs for Protein Crystallography. *Acta Crystallogr.* **D50**:760-763.
- Cowtan, K. 2006. The *Buccaneer* software for automated model building. 1. Tracing protein chains. *Acta Crystallogr.* **D62**:1002-1011.
- DeLano, W.L. 2002. *The PyMOL Molecular Graphics System*. DeLano Scientific, San Carlos, CA.
- Dodson, G., Wlodawer, A. 1998. Catalytic triads and their relatives. *Trends Biochem. Sci.* **23**:347-352.
- Dutta, S., Dutta, S., Dutta, P., Matsushita, S., Bhattacharya, S.K., Yoshida, S. 2003. *Shigella dysenteriae* serotype 1, Kolkata, India. *Emerg. Infect. Dis.* **9**:1471-1474.
- Elliott, S.J., Krejany, E.O., Mellies, J.L., Robins-Browne, R.M., Sasakawa, C., Kaper, J.B. 2001. EspG, a novel type III system-secreted protein from enteropathogenic *Escherichia coli* with similarities to VirA of *Shigella flexneri*. *Infect. Immun.* **69**:4027-4033.

- Emsley, P., Cowtan, K. 2004. Coot: model-building tools for molecular graphics. *Acta Crystallogr.* **D60**:2126-2132.
- Galan, J.E., Wolf-Watz, H. 2006. Protein delivery into eukaryotic cells by type III secretion machines. *Nature* **444**:567-573.
- Germane, K.L., Ohi, R., Goldberg, M.B., Spiller, B.W. 2008. Structural and Functional Studies Indicate That *Shigella* VirA Is Not a Protease and Does Not Directly Destabilize Microtubules. *Biochemistry* DOI 10.1021/bi801533k
- Holm, L., Sander, C. 1993. Protein structure comparison by alignment of distance matrices. *J. Mol. Biol.* **233**:123-38.
- Kapust, R.B., Tözsér, J., Fox, J.D., Anderson, D.E., Cherry, S., Copeland, T.D., Waugh, D.S. 2001. Tobacco etch virus protease: mechanism of autolysis and rational design of stable mutants with wild-type catalytic proficiency. *Protein Eng.* **14**:993-1000.
- Lan, R., Reeves, P.R. 2002. *Escherichia coli* in disguise: molecular origins of *Shigella*. *Microbes. Infect.* **4**:1125-1132.
- Laskowski, R.A., MacArthur, M.W., Moss, D.S., Thornton, J.M. 1993. PROCHECK: program to check the stereochemical quality of protein structures. *J. Appl. Crystallogr.* **26**:283-291.
- Matthews, B.W. 1968. Solvent content of protein crystals. *J. Mol. Biol.* **33**:491-497.
- McCoy, A.J., Grosse-Kunstleve, R.W., Adams, P.D., Winn, M.D., Storoni, L.C., Read, R.J. 2007. *Phaser* crystallographic software. *J. Appl. Cryst.* **40**:658-674.

Mundy, R., Petrovska, L., Smollett, K., Simpson, N., Wilson, R.K., Yu, J., Tu, X., Rosenshine, I., Clare, S., Dougan, G., Frankel, G. 2004. Identification of a novel *Citrobacter rodentium* type III secreted protein, EspI, and roles of this and other secreted proteins in infection. *Infect. Immun.* **72**:2288-2302.

Ogawa, M., Handa, Y., Ashida, H., Suzuki, M., Sasakawa, C. 2008. The versatility of *Shigella* effectors. *Nat. Rev. Microbiol.* **6**:11-16.

Otwinowski, Z., Minor, W. 1997. Processing of X-ray diffraction data collected in oscillation mode. *Methods Enzymol.* **276**:307-326.

Parsot, C. 2005. *Shigella* spp. and enteroinvasive *Escherichia coli* pathogenicity factors. *FEMS Microbiol. Lett.* **252**:11-18.

Schroeder, G.N., Hilbi, H. 2008. Molecular pathogenesis of *Shigella* spp.: controlling host cell signaling, invasion, and death by type III secretion. *Clin. Microbiol. Rev.* **21**:134-156.

Shaw, R.K., Smollett, K., Cleary, J., Garmendia, J., Straatman-Iwanowska, A., Frankel, G., Knutton, S. 2005. Enteropathogenic *Escherichia coli* type III effectors EspG and EspG2 disrupt the microtubule network of intestinal epithelial cells. *Infect. Immun.* **73**:4385-4390.

Sheldrick, G.M. 2008. A short history of SHELX. *Acta Crystallogr.* **A64**:112-122.

Sheldrick, G. M. 2001. XPREP program. 6.14 Bruker Nonius, Inc., Madison, Wisconsin, USA

- Smollett, K., Shaw, R.K., Garmendia, J., Knutton, S., Frankel, G. 2006. Function and distribution of EspG2, a type III secretion system effector of enteropathogenic *Escherichia coli*. *Microbes. Infect.* **8**:2220-2227.
- Stubbs, M.T., Laber, B., Bode, W., Huber, R., Jerala, R., Lenarcic, B., Turk, V. 1990. The refined 2.4 Å X-ray crystal structure of recombinant human stefin B in complex with the cysteine proteinase papain: a novel type of proteinase inhibitor interaction. *EMBO J.* **9**:1939-1947.
- Terwilliger, T.C. 2003. SOLVE and RESOLVE: automated structure solution and density modification. *Methods Enzymol.* **374**:22-37.
- Terwilliger, T.C. 2002. Rapid automatic NCS identification using heavy-atom substructures. *Acta Crystallogr.* **D58**:2213-2215.
- Terwilliger, T.C., Berendzen, J. 1999. Automated MAD and MIR structure solution. *Acta Crystallogr.* **D55**:849-861.
- Tomson, F.L., Viswanathan, V.K., Kanack, K.J., Kanteti, R.P., Straub, K.V., Menet, M., Kaper, J.B., Hecht, G. 2005. Enteropathogenic *Escherichia coli* EspG disrupts microtubules and in conjunction with Orf3 enhances perturbation of the tight junction barrier. *Mol. Microbiol.* **56**:447-464.
- Tropea, J.E., Cherry, S., Nallamsetty, S., Bignon, C., Waugh, D.S. 2007. A generic method for the production of recombinant proteins in *Escherichia coli* using a dual hexahistidine-maltose-binding protein affinity tag. *Methods Mol. Biol.* **363**:1-19.

Yoshida, S., Handa, Y., Suzuki, T., Ogawa, M., Suzuki, M., Tamai, A., Abe, A., Katayama, E., Sasakawa, C. 2006. Microtubule-severing activity of *Shigella* is pivotal for intercellular spreading. *Science* **314**:985-989.

Yoshida, S., Katayama, E., Kuwae, A., Mimuro, H., Suzuki, T., Sasakawa, C. 2002. *Shigella* deliver an effector protein to trigger host microtubule destabilization, which promotes Rac1 activity and efficient bacterial internalization. *EMBO J.* **21**:2923-2935.

**Table 1.** Data collection and refinement statistics

Wavelength (Å)	0.979
Space group	C2
Unit cell parameters (Å)	$a=150.3$ , $b=170.9$ , $c=46.2$ , $\beta=104.9^\circ$
Resolution (Å)	28.85-3.0 (3.11-3.0)
Number of reflections (unique/total)	22,221 (463,549)
Completeness % (total/last shell)	96.8 (80.5)
$R_{\text{merge}}$ % (total/last shell)	8.2 (42.1)
Redundancy (total/last shell)	7.1 (6.0)
Average $I/\sigma$ (total/last shell)	20.6 (3.4)
No. of molecules in a.u.	2
No. of protein atoms	5306
No. of solvent molecules	80
No. of phosphate molecules	5
$R_{\text{cryst}}$	22.1%
$R_{\text{free}}$ (5%)	25.3%
r.m.s. deviations from ideality	
Bond lengths	0.012 Å
Angles	1.3°
Ramachandran plot (most favored/ allowed / generously allowed / disallowed)	79.4% / 17.3% / 3% / 0.3%

**Figure 1.** The structure of VirA. A. Ribbon diagram showing the structure of a monomer of VirA. The N-terminal domain is colored gold, and the C-terminal domain, blue. Location of selected residues are marked. B. A topology diagram of the secondary structure of VirA, showing  $\alpha$  helices as cylinders,  $\beta$  strands as arrows, and irregular structure as lines. Broken lines mark the missing residues. Secondary structure elements are labeled as discussed in the text C. A dimer of VirA, with the two molecules shown in green and yellow. All images representing structures were created in PyMol (DeLano 2002).

**Figure 2.** Conservation of the sequence in the VirA/EspG family. A. Sequence alignment of VirA, EspG, EspG2, and EspI proteins performed using ClustalW. Red denotes identical, green denotes strongly similar and blue denotes weakly similar conservation. B. Superposition of the C $\alpha$  coordinates of the N-terminal domain of VirA and the inhibitor stefin B from the complex with papain (PDB code 1STF). VirA is traced in green and stefin B in cyan. C. Surface diagram of VirA in which the residues that are strictly conserved among VirA, EspG, EspG2, and EspI are colored red.

Figure 1

**A**

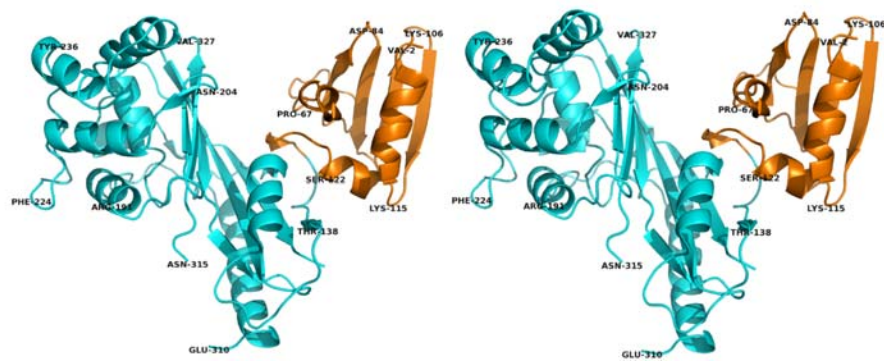

**B**

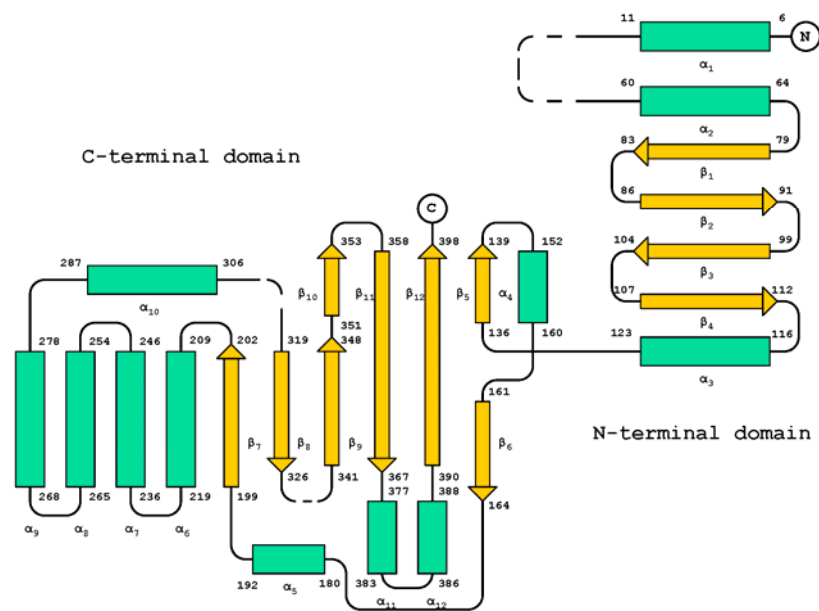

**C**

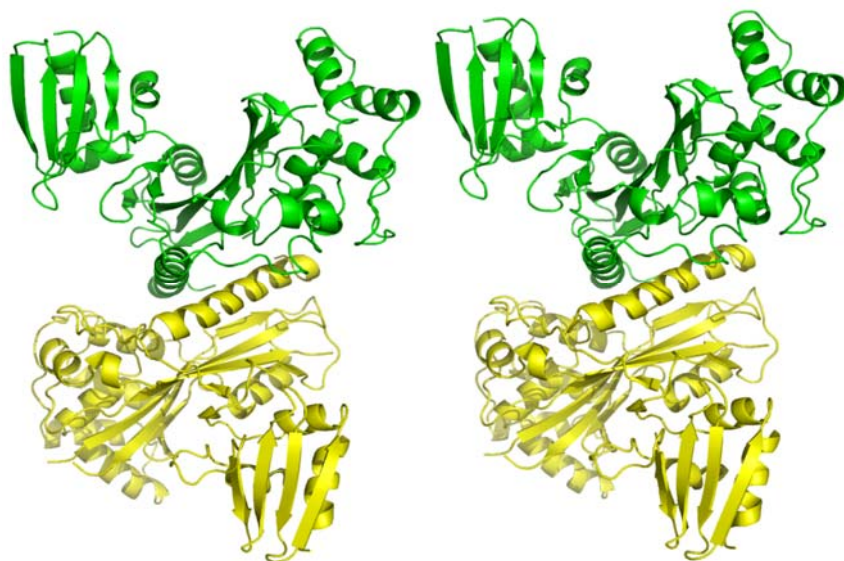
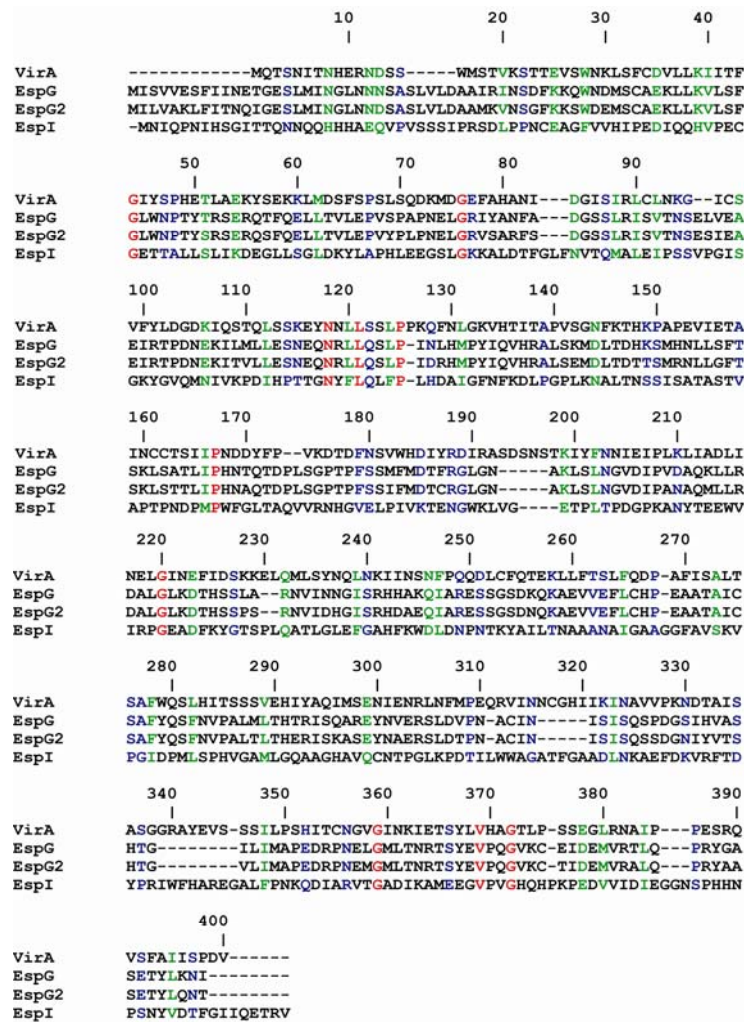
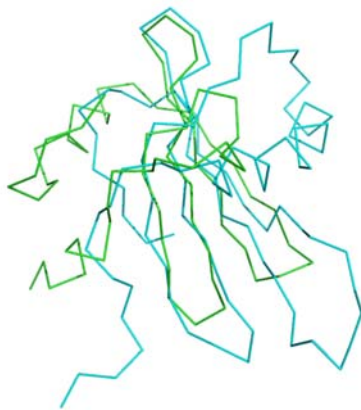

Figure 2

A



B



C

